

PROJECTION - THIRD ANGLE
ALL DIMENSIONS IN MILLIMETRES

DO NOT SCALE

REMOVE ALL BURRS AND SHARP EDGES

ISSUE	A NOTE	DATE	INITIALS
A	1049189	04.12.09	EWC

MODIFICATION
INITIAL ISSUE

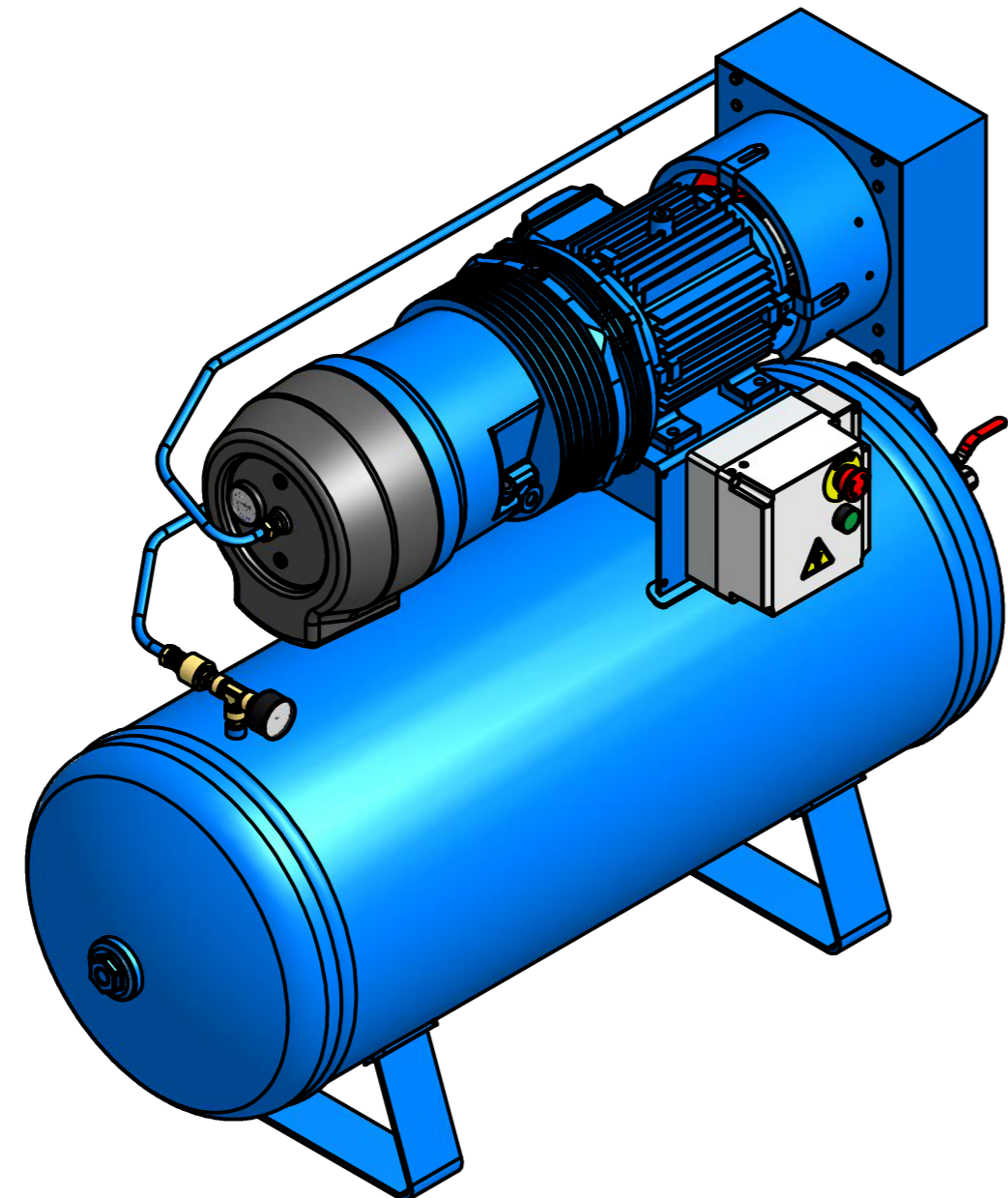
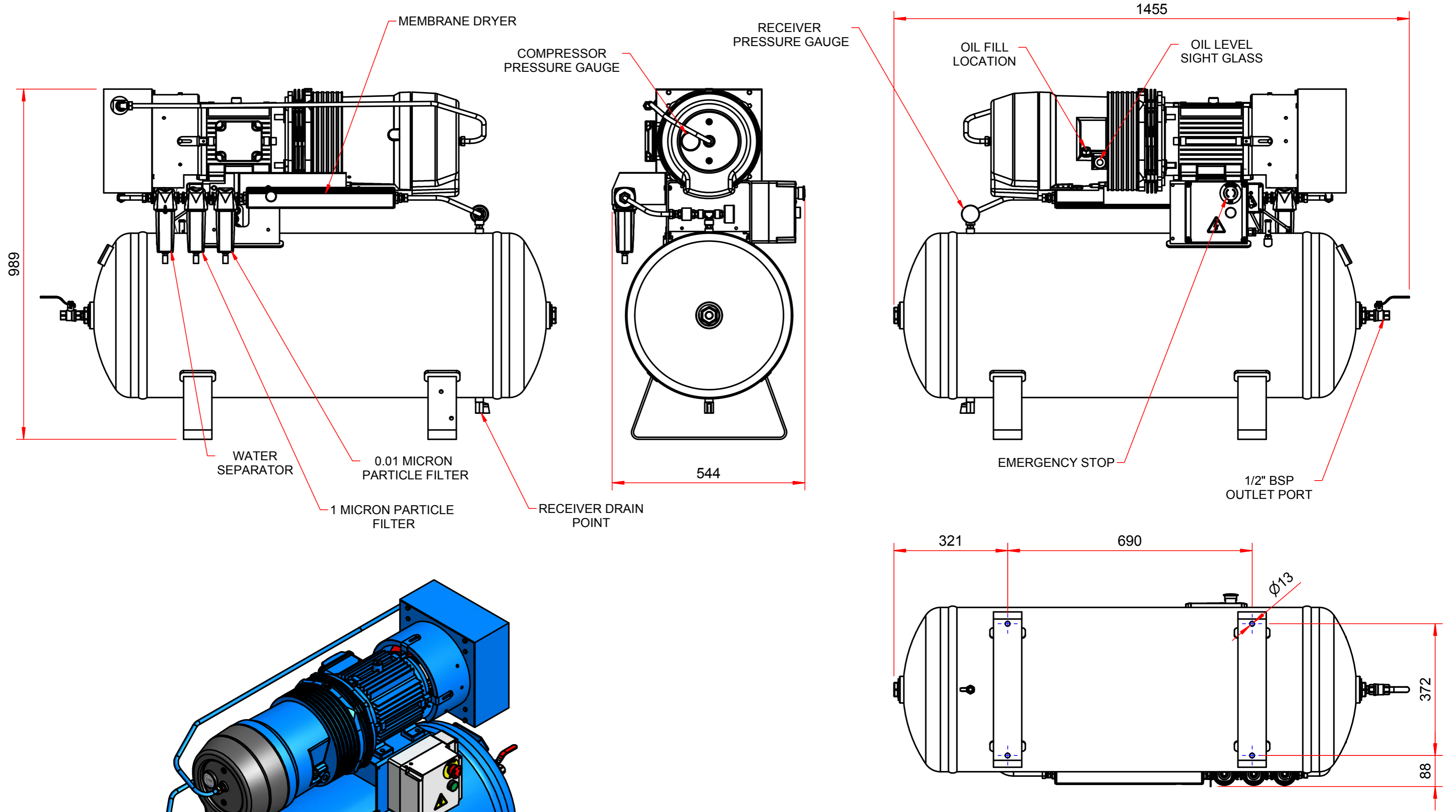

1 OF 1

FIRST USE
504 PURDS

NOTES AND TOLERANCES UNLESS OTHERWISE STATED

<p>DIMENSIONS AND DRAWING PRACTICE TO BS 308, GEOMETRIC TOLERANCES TO BS 308 Pt. 3.</p> <p>MACHINED DIMENSIONS UP TO 300 ± 0.4 OVER 300 TO 600 ± 0.8 OVER 600 ± 1.6</p> <p>POSITIONAL TOLERANCE PLAIN HOLES Ø 0.13 TAPPED HOLES Ø 0.26</p> <p>CONCENTRICITY TOLERANCE 0.13 TIR</p> <p>MACHINED SURFACES INDICATED THUS ✓</p> <p>SURFACE TEXTURE TO BS 1134, VALUES IN MICROMETRES.</p>	<p>CASTING DIMENSIONS SEE HYDROVANE D.O.M. 9.</p> <p>FORGING DIMENSIONS SEE BS 4114.</p> <p>ANGLES ± 1/2° (EXCEPT CHAMFERS).</p> <p>METRIC THREADS TO BS 3643 MEDIUM CLASS EXTERNAL 6g INTERNAL 6H.</p> <p>PIPE THREADS PRESSURE TIGHT TO BS 21 FASTENING TO BS 2779.</p> <p>SEE HYDROVANE D.O.M. 19. UNIFIED THREADS TO BS 1580.</p>	<p>SHEET METAL WORK AND FABRICATED COMPONENTS. POSITIONAL TOLERANCE FOR PLAIN & TAPPED HOLES Ø1.0</p> <p>SHEET METAL WORK DIMENSIONS ± 1.0 FABRICATED PARTS DIMENSIONS ± 1.0</p> <p>WELDING SYMBOLS TO BS 499.</p> <p>RECEIVERS - MACHINING UNDER 600 ± 0.3 OVER 600 ± 0.8 ANGLES ± 0.5°</p> <p>FABRICATION UNDER 100 ± 0.5 100-300 ± 1.0 300-600 ± 1.5 OVER 600 ± 2.0 ANGLES ± 1.5°</p>
--	---	--

ALL DIMENSIONS ARE FINISHED DIMENSIONS

MATERIAL :
N/A

SCALE	DRAWN	DATE
1:5	EWC	04/12/2009

TITLE
504PURDS INSTALLATION
DRAWING

hydrovane

GARDNER DENVER LTD., REDDITCH, WORCESTERSHIRE, ENGLAND OWNS THE
COPYRIGHT OF THIS DRAWING WHICH IS SUPPLIED IN CONFIDENCE AND MUST NOT
BE USED FOR ANY PURPOSE OTHER THAN THAT FOR WHICH IT IS SUPPLIED AND
MUST NOT BE REPRODUCED WITHOUT PERMISSION IN WRITING FROM THE OWNERS.

DRAWING No.
CZ35220